



CP- and OCF-networks – a comparison

Christian Eichhorn^{a,*}, Matthias Fey^{b,**}, Gabriele Kern-Isberner^{a,**}

^a Chair 1 Computer Science, Technische Universität Dortmund, Dortmund, Germany

^b Technische Universität Dortmund, Dortmund, Germany

Received 11 October 2014; received in revised form 1 April 2016; accepted 11 April 2016

Available online 19 April 2016

Abstract

Network approaches are used to structure, partition and display formalisms in the area of knowledge representation as well as decision making. Known approaches are, for instance, OCF-networks, Bayesian style networks where every variable is annotated with a conditional ranking table, and CP-networks, directed acyclic networks with local preferences annotated at each vertex. The structures of these networks are similar, but their semantics seem to be quite different. In this paper we discuss if OCF-networks can be used to model the information of CP-networks and vice versa. To answer this question we investigate which restrictions and conditions have to be presupposed to either of the approaches such that one structure can be used to generate the other.

© 2016 Elsevier B.V. All rights reserved.

Keywords: CP-network; OCF-network; Acyclic network; Ranking function; Ceteris paribus; Preference; Preferential models

1. Introduction

Representing knowledge, belief or preference as a network rather than, e.g., an exponentially large table of configurations, possible worlds or elementary events allow for spacious and complicated formalisms to become more widely used and successful, the triumph of probabilistics, for instance, is hard to imagine without Bayesian networks [23]. These networks that are well established and successful in probabilistics have been applied to other knowledge representation approaches, too. In the area of semi-quantitative reasoning, for the formalism of ordinal conditional functions (OCF, [25,26]) the approach of OCF-networks [16,7,18,13] has proven to be a lightweight and helpful approach for compact representation of belief states.

On the other hand, directed acyclic networks with local information storage which are, naturally, the core and centre of a Bayesian network, are used in other areas as well. In the area of decision making, the approach of ceteris paribus (CP-) networks models a global preferential relation on the set of worlds based on local preferences [9]. This

* Principal corresponding author.

** Corresponding authors.

E-mail addresses: christian.eichhorn@tu-dortmund.de (C. Eichhorn), matthias.fey@tu-dortmund.de (M. Fey), gabriele.kern-isberner@cs.tu-dortmund.de (G. Kern-Isberner).

approach also relies on a directed acyclic graph with tables at the vertices that in this case encodes local preferences in the context of parent vertices, so we have a strong resemblance to other network approaches.

If for two network approaches the underlying structures are identical (with respect to the graph-component) or follow similar concepts, such as storing local information on configurations of variables in the context of the configuration of their parent vertices, the question whether these networks are related arises naturally. In this paper we examine whether the structural resemblance between OCF-networks and CP-networks is carried over to formal properties of the formalisms, that is, if both approaches share certain properties. This question is addressed by trying to derive either approach from the other, inspecting if the preferential inferences that can be drawn from both formalisms are identical.

We demonstrate that plainly transferring local preferences between both approaches creates the designated structure. This approach succeeds in generating either structure, but since it just uses local information and does not take the respective global properties, like, for instance, (conditional) independence, into account, it fails to transfer the respective inference behaviour. We use the insights from the plain approach and introduce an approach that allows to construct an OCF-network from every CP-network. We also show that even if we restrict OCF-networks to some extent, there are OCF-networks that cannot be transferred into CP-networks without losing information. With the insights gained from these investigations, we postulate a property for OCF-networks that ensures that the global ranking function is compatible with the local preferences of the network and hence with the CP-network that is generated from the OCF-network by the plain approach. Applied to the generation of OCF-networks from CP-networks this property provides a schema of local ranking tables for OCF-networks that are compatible with the initial CP-network. We present an algorithm that constructs an OCF-network with minimal local ranking values for a CP-network implementing this schema and compare both approaches with respect to their possibility to encode formal properties of the respective other. These results finally give us that OCF-networks are strictly more expressive than CP-networks.

The paper is organised as follows: Section 2 gives the preliminaries necessary for this paper. We then introduce the two approaches of CP-networks (Section 3) and OCF-networks (Section 4) together with the necessary underlying knowledge representation formalisms to an extent that is necessary for the comparison. In the following Section 5 we focus on the question whether CP-networks can be derived from OCF-networks, or vice versa. Here we introduce a plain approach that generates the designated structure but fails to transfer the inference behaviour in the general case in Section 5.1. This problem is addressed in Section 5.2 by restricting OCF-networks to such an extent that local indifference, a concept not compatible with the local information in CP-networks, is excluded and present an algorithm that maps each CP-network to an OCF-network. In Section 6 we use the insights gained by discussing how to mutually derive one network type from the other to compare both approaches. Section 7 then sums up this comparison on basis of the results of the previous sections. We relate our approach to other works in Section 8 and conclude in Section 9.

2. Preliminaries

In this section we introduce the syntax and semantics used in this paper: Let $\Sigma = \{V_1, \dots, V_m\}$ be a finite propositional alphabet. We denote by v_i the variable V_i in its positive and by \bar{v}_i in its negative outcome, while \hat{v}_i denotes an arbitrary but fixed outcome of V_i . A *literal* is the positive or negative outcome of a variable. The logical language \mathcal{L} is recursively defined over closure of conjunction (\wedge), disjunction (\vee) and negation (\neg) in the usual way: Every literal is a formula, every negated formula is a formula and if ϕ and ψ are formulas, the conjunction $\phi \wedge \psi$ and disjunction $\phi \vee \psi$ of ϕ and ψ are formulas. For easier reading and shorter formulas, we often omit the connector \wedge and indicate conjunction by juxtaposition of formulas (that is, $\phi\psi$ stands for $\phi \wedge \psi$) and indicate negation by overlining (that is, $\overline{\phi}$ stands for $\neg\phi$).

Interpretations, or *possible worlds* as a syntactical representation of interpretations, are also defined in the usual way; the set of all possible worlds is denoted by Ω . We often use the 1-1 association between worlds and *complete conjunctions*, that is, conjunctions of literals where every variable $V_i \in \Sigma$ appears exactly once. For subsets $\mathbf{A} \subseteq \Sigma$ we refer to the set of *local worlds* by conjunctions of literals where every variable $V_i \in \mathbf{A}$ appears exactly once and denote the set of all local worlds as $\Omega_{\mathbf{A}}$ with individual worlds $\mathbf{a} \in \Omega_{\mathbf{A}}$.

A model ω of a propositional formula $\phi \in \mathcal{L}$ is a possible world that satisfies ϕ , written as $\omega \models \phi$. The set of all models $\omega \models A$ is denoted by $Mod(A)$. For formulas $\phi, \psi \in \mathcal{L}$, ϕ *entails* ψ , written as $\phi \models \psi$, iff $Mod(\phi) \subseteq Mod(\psi)$, that is, if and only if for all $\omega \in \Omega$, $\omega \models \phi$ implies $\omega \models \psi$. For sets of formulas $\mathcal{A} \subseteq \mathcal{L}$ we

have $Mod(\mathcal{A}) = \bigcap_{\phi \in \mathcal{A}} Mod(\phi)$. By $V(\omega)$ resp. $\mathbf{A}(\omega)$ we indicate the outcome \dot{v} of V resp. the local world $\mathbf{a} \in \Omega_{\mathbf{A}}$ where $\omega \models \dot{v}$ resp. $\omega \models \mathbf{a}$.

In this paper a *preferential model* $\mathfrak{M} = (\Omega, \models, <)$ is a triple consisting of the set of possible worlds, the classical entailment relation \models and an irreflexive transitive relation $< \subseteq \Omega \times \Omega$. With Ω being finite and $<$ being transitive and irreflexive, for every $\omega \in \Omega$ such that $\omega \models \phi$, $\phi \in \mathcal{L}$, either ω is a $<$ -smallest world that satisfies ϕ or there is a smallest world $\omega' \models \phi$ with $\omega' < \omega$, that is, there is a $<$ -minimal model for every formula and there are no endless $<$ -descending chains over Ω . A preferential model with this property is called *stoppered*. So with \models being classical, \mathfrak{M} is a *classical stoppered preferential model* [22,21]. Preferential models give rise to nonmonotonic entailment relations \vdash such that for formulas $\phi, \psi \in \mathcal{L}$, ϕ nonmonotonically entails ψ (written $\phi \vdash \psi$) if and only if for all worlds $\omega' \models \phi \bar{\psi}$ there is a world $\omega \models \phi \psi$ with the property that $\omega < \omega'$.

A *preference relation* $<$ is a transitive, irreflexive, asymmetric total relation. For two objects v, v' we write $v < v'$ if and only if v is strictly preferred to v' . If we want to express indifference, we use a transitive, reflexive and total relation \preceq called *preference relation with indifference* where $v \preceq v'$ expresses that v is at least as preferred as v' . For easier reading we overload $<$ as relations on sets, writing $\mathcal{V} < \mathcal{V}'$ if and only if for all $v \in \mathcal{V}$ and $v' \in \mathcal{V}'$ we have $v < v'$, likewise for \preceq .

A *directed graph* $(\mathcal{V}, \mathcal{E})$ is a tuple of a set of vertices \mathcal{V} and edges \mathcal{E} , which are pairs of vertices. We here use the propositional alphabet as set of vertices, hence edges are ordered pairs (V, V') , $V, V' \in \Sigma$. For $V \in \Sigma$, we call the set $pa(V) = \{V' \mid (V', V) \in \mathcal{E}\}$ the *parents* of V and $ch(V) = \{V' \mid (V, V') \in \mathcal{E}\}$ the *children* of V . A *path* $V_1 \rightsquigarrow V_n$ is a nonempty array of vertices (V_1, \dots, V_n) such that $(V_i, V_{i+1}) \in \mathcal{E}$ for all vertices in the path. The set of *descendants* of a vertex V is the set of vertices V' such that there is a path from V to V' , formally $desc(V) = \{V' \mid V \rightsquigarrow V'\}$. The set of *non-descendants* of a vertex V is the set of vertices which are neither V , nor descendants nor parents of V , formally $nd(V) = \Sigma \setminus (\{V\} \cup pa(V) \cup desc(V))$. A directed graph is called *acyclic* if and only if there is no path $V \rightsquigarrow V$ for all $V \in \Sigma$.

3. CP-networks

Lots of our everyday preferences seem to be of the type *ceteris paribus*, that is, our preferences are represented keeping “everything else equal”, meaning that, for example, if we are asked whether we prefer one thing to another we answer in the context of the actual situation, mentally keeping all other variables constant.

We denote preferences between the outcomes of a variable in the context of (i.e. dependent on) a set of variables as conditional preference tables at the vertices of a directed acyclic graph to obtain a CP-network:

Definition 1 (*CP-network* [9]). Let $\mathcal{G} = (\Sigma, \mathcal{E})$ be a directed acyclic graph (DAG). Let $\{CPT(V, pa(V))\}_{V \in \Sigma}$ be a set of *conditional preference tables* (CPTs) that assign to each $V \in \Sigma$ preference relations $<_{\mathbf{p}}$ between v and \bar{v} given each outcome $\mathbf{p} \in \Omega_{pa(V)}$ of the parents of V . The tuple $\Pi = (\Sigma, \mathcal{E}, \{CPT(V, pa(V))\}_{V \in \Sigma})$ is called a *CP-network*.

Example 1 (*Dinner* [9]). Let $\Sigma = \{F, V, W\}$ be a set of propositional variables for a dinner configuration, where F indicates a fish course (f) or non-fish course (\bar{f}), V indicates having a vegetable soup (v) or not (\bar{v}), and W indicates whether we drink wine at dinner (w) or not (\bar{w}). We strictly prefer a fish course over non-fish courses, so the conditional preference table $CPT(F, \top)$ is $(f <_{\top} \bar{f})$. Our preference between the choice of soup is conditioned on the main course: We prefer to open with vegetable soup if the main course is fish and with something else otherwise, so the conditional preference table $CPT(V, \{F\})$ is $(v <_f \bar{v}, (\bar{v} <_{\bar{f}} v))$. Finally, we choose wine if we open with a vegetable soup, else we don't drink wine so the conditional preference table $CPT(W, \{V\})$ is $(w <_v \bar{w}, (\bar{w} <_{\bar{v}} w))$.

Fig. 1 shows the CP-network of this example.

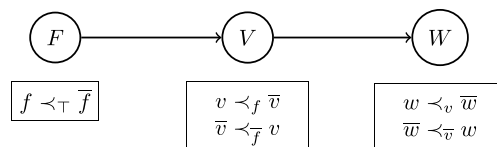

Fig. 1. CP-network for Example 2.

For CP-networks, the following notion of *satisfiability* defines preference relations on the set of possible worlds that are compatible to the local preference relations of a CP-network.

Definition 2 (*Satisfiability of CP-networks [9]*). Let $\Pi = \langle \Sigma, \mathcal{E}, \{CPT(V, pa(V))\}_{V \in \Sigma} \rangle$ be a CP-network. A preference relation $\prec_{cp} \subseteq \Omega \times \Omega$ satisfies Π if and only if for every $V \in \Sigma$, for every configuration $\mathbf{p} \in \Omega(pa(V))$ of its parents and any configuration of the other variables in the graph $\mathbf{o} \in \Omega(\Sigma \setminus (\{V\} \cup pa(V)))$, we have $\dot{v} \prec_{\mathbf{p}} \bar{v}$ if and only if $\omega = \dot{v}\mathbf{p}\mathbf{o} \prec_{cp} \bar{v}\mathbf{p}\mathbf{o} = \omega'$.

It has been shown in [9] that every CP-network is satisfiable, that is, for every Π defined according to Definition 1 there is a preference relation $\prec_{cp} \subseteq \Omega \times \Omega$ that satisfies Π . Note that there may be different Π -satisfying preference relations and usually there is no unique Π satisfying preference relation. The preference of worlds induced by all Π -satisfying preference relation is formalised as follows:

Definition 3 (*Global CP-network preference [9]*). Let $\Pi = \langle \Sigma, \mathcal{E}, \{CPT(V, pa(V))\}_{V \in \Sigma} \rangle$ be a CP-network. A world ω is preferred globally to a world ω' with respect to Π (written $\omega \prec_{\Pi} \omega'$) if and only if $\omega \prec_{cp} \omega'$ for every Π satisfying preference relation \prec_{cp} .

Example 2 (*Dinner [9] (continued)*). There are exactly two relations that satisfy the CP-network of Example 1 (cf. Fig. 1). These can be obtained by bottom-up ordering the possible worlds by the preferences defined in the local CPTs of the network with a stable sorting algorithm; alternatively, [9] gives a procedure using another network structure to calculate the preferences. The relations are:

$$\begin{aligned} f v w \prec_{cp}^{(1)} f v \bar{w} \prec_{cp}^{(1)} f \bar{v} \bar{w} \prec_{cp}^{(1)} \underline{f \bar{v} w} \prec_{cp}^{(1)} \underline{\bar{f} \bar{v} \bar{w}} \prec_{cp}^{(1)} \bar{f} \bar{v} w \prec_{cp}^{(1)} \bar{f} v w \prec_{cp}^{(1)} \bar{f} v \bar{w} \\ f v w \prec_{cp}^{(2)} f v \bar{w} \prec_{cp}^{(2)} f \bar{v} \bar{w} \prec_{cp}^{(2)} \underline{\bar{f} \bar{v} \bar{w}} \prec_{cp}^{(2)} \underline{f \bar{v} w} \prec_{cp}^{(2)} \bar{f} \bar{v} w \prec_{cp}^{(2)} \bar{f} v w \prec_{cp}^{(2)} \bar{f} v \bar{w}. \end{aligned}$$

These two relations differ in the ordering of the two underlined elements, only, the global CP-preference hence is

$$f v w \prec_{\Pi} f v \bar{w} \prec_{\Pi} f \bar{v} \bar{w} \prec_{\Pi} \{f \bar{v} w, \bar{f} \bar{v} \bar{w}\} \prec_{\Pi} \bar{f} \bar{v} w \prec_{\Pi} \bar{f} v w \prec_{\Pi} \bar{f} v \bar{w}.$$

Thus, we have, for example, $f v w \prec_{\Pi} f v \bar{w}$ but $f \bar{v} w \not\prec_{\Pi} \bar{f} \bar{v} \bar{w}$ and $\bar{f} \bar{v} \bar{w} \not\prec_{\Pi} f \bar{v} w$.

It has been shown in [9] that \prec_{Π} is transitive, it is clear that \prec_{Π} is neither reflexive nor symmetric, but Example 2 shows that \prec_{Π} is not total since $\bar{f} \bar{v} \bar{w} \not\prec_{\Pi} f \bar{v} w$ as well as $f \bar{v} w \not\prec_{\Pi} \bar{f} \bar{v} \bar{w}$, hence \prec_{Π} is no preference relation.

As \prec_{Π} is a relation on the possible worlds we can define a preferential model and therefore a preferential entailment relation on this relation according to [22]. We define the following nonmonotonic entailment relation for CP-networks:

Definition 4 (*CP-entailment*). Let $\Pi = \langle \Sigma, \mathcal{E}, \{CPT(V, pa(V))\}_{V \in \Sigma} \rangle$ be a CP-network with the global preference relation \prec_{Π} . Let $\phi, \psi \in \mathcal{L}$. The tuple $\mathfrak{M}_{\Pi} = (\Omega, \models, \prec_{\Pi})$ is a classical stoppered preferential model and so we define, according to [22], *CP-entailment* such that ϕ CP-entails ψ if and only for every model of ϕ there is a \prec_{Π} -preferred model of ψ , formally

$$\phi \vdash_{\Pi} \psi \text{ iff for all } \omega' \models \phi \text{ there exists an } \omega \models \psi \text{ such that } \omega \prec_{\Pi} \omega'. \quad (1)$$

Apart from the inferential properties provided by the network and its global relation \prec_{Π} as a preferential inference system, CP-networks induce an independence property between the vertices as follows.

Definition 5 (*Conditional CP-independence [9]*). Let Σ be a set of variables with possible worlds Ω and a preference relation $\prec \subseteq \Omega \times \Omega$. Let $\mathbf{V} \subseteq \Sigma$, $\mathbf{P} \subseteq \Sigma$ and $\mathbf{O} \subseteq \Sigma$ such that \mathbf{V} , \mathbf{P} and \mathbf{O} are mutually disjoint and $\Sigma = \mathbf{V} \cup \mathbf{P} \cup \mathbf{O}$. \mathbf{V} is conditionally CP-independent from \mathbf{O} given \mathbf{P} (written $\mathbf{V} \perp_{\prec} \mathbf{O} \mid \mathbf{P}$) if and only if

$$\mathbf{vop} \prec \mathbf{v'op} \quad \text{if and only if} \quad \mathbf{vo'p} \prec \mathbf{v'o'p}$$

for all fixed $\mathbf{p} \in \Omega_{\mathbf{P}}$ and all $\mathbf{v}, \mathbf{v}' \in \Omega_{\mathbf{V}}$, $\mathbf{o}, \mathbf{o}' \in \Omega_{\mathbf{O}}$.

Lemma 1. (See [9].) In a CP-network Π , every vertex V is conditionally CP-independent from all vertices in the graph except for its parents given its parents, formally

$$V \perp\!\!\!\perp_{<\Pi} \Sigma \setminus (\{V\} \cup pa(V)) \mid pa(V)$$

We prove this property presupposed in [9].

Proof. This property follows directly from the satisfiability of CP-networks. More precisely, a set of vertices $\mathbf{V} \subseteq \Sigma$ is conditionally CP-independent from a set of vertices $\mathbf{O} \subseteq \Sigma$ given a set $\mathbf{P} \subseteq \Sigma$ if and only if $\mathbf{vop} < \mathbf{v'op}$ is equivalent to $\mathbf{vo'p} < \mathbf{v'o'p}$ (Definition 5) for arbitrary outcomes $\mathbf{v}, \mathbf{v}', \mathbf{o}, \mathbf{o}', \mathbf{p}$ of $\mathbf{V}, \mathbf{O}, \mathbf{P}$. Let $V \in \Sigma$, $\mathbf{P} = pa(V)$ and $\mathbf{O} = \Sigma \setminus (\{V\} \cup pa(V))$. The relation $<_{\Pi}$ is defined by the intersection of all Π -satisfying preference relations. The satisfiability condition (Definition 2) then requires that we have $\dot{v} <_{\mathbf{p}} \bar{v}$ if and only if $\dot{v}\mathbf{op} <_{cp} \bar{v}\mathbf{op}$ for all outcomes of \mathbf{o} of \mathbf{O} given a fixed outcome \mathbf{p} of \mathbf{P} and all Π -satisfying relations $<_{cp}$. Therefore by definition of $<_{\Pi}$ we obtain $\dot{v}\mathbf{op} <_{\Pi} \bar{v}\mathbf{op}$ for all outcomes of \mathbf{o} of \mathbf{O} given a fixed outcome \mathbf{p} of \mathbf{P} if and only if $\dot{v} <_{\mathbf{p}} \bar{v}$. This implies that for any two outcomes \mathbf{o}, \mathbf{o}' of \mathbf{O} we have $\dot{v}\mathbf{op} <_{\Pi} \bar{v}\mathbf{op}$ iff $\dot{v}\mathbf{o'p} <_{\Pi} \bar{v}\mathbf{o'p}$ if and only if $\dot{v} <_{\mathbf{p}} \bar{v}$. So by Definition 5 we obtain $V \perp\!\!\!\perp_{<\Pi} \mathbf{O} \mid \mathbf{P}$, and by definition of \mathbf{O} and \mathbf{P} , this is $V \perp\!\!\!\perp_{<\Pi} \Sigma \setminus (\{V\} \cup pa(V)) \mid pa(V)$, which we wanted to show. \square

4. OCF-networks

Ordinal conditional functions (OCF, also called *ranking functions*) introduce an implausibility ranking onto the possible worlds, that is, the higher the rank of a world, the less plausible it is.

Definition 6 (Ordinal conditional function [25,26]). Let Ω be the set of all possible worlds ω . An ordinal conditional function (OCF) $\kappa : \Omega \rightarrow \mathbb{N}_0 \cup \{\infty\}$ maps each possible world to a degree of implausibility with the constraint that there are worlds which are maximally plausible, that is $\{\omega \mid \kappa(\omega) = 0\} \neq \emptyset$. We call $\kappa(\omega)$ the rank of ω . The rank of a formula $\phi \in \mathcal{L}$ is the minimal rank of all models of the formula, formally $\kappa(\phi) = \min\{\kappa(\omega) \mid \omega \models \phi\}$, the rank of a conditional is the rank of its verification normalised with the rank of its premise, formally $\kappa(\psi \mid \phi) = \kappa(\phi\psi) - \kappa(\phi)$. We define by κ^{-1} the preimage of κ such that $\kappa^{-1}(n) = \{\omega \mid \kappa(\omega) = n\}$ for all $n \in \mathbb{N}_0 \cup \{\infty\}$.

In addition to the definition of ranking functions we need the notion of (conditional) κ -independence which is defined in the following:

Definition 7 (κ -independence [26,13]). Let $\mathcal{A}, \mathcal{B}, \mathcal{C} \subseteq \Sigma$ be sets of variables, let κ be an OCF according to Definition 6. The set \mathcal{A} is κ -independent from \mathcal{B} (written $\mathcal{A} \perp\!\!\!\perp_{\kappa} \mathcal{B}$) if and only if for all $\mathbf{a} \in \Omega_{\mathcal{A}}$, $\mathbf{b} \in \Omega_{\mathcal{B}}$ we have $\kappa(\mathbf{a}|\mathbf{b}) = \kappa(\mathbf{a})$. The set \mathcal{A} is conditionally κ -independent from \mathcal{B} given \mathcal{C} (written $\mathcal{A} \perp\!\!\!\perp_{\kappa} \mathcal{B} \mid \mathcal{C}$) if and only if for all $\mathbf{a} \in \Omega_{\mathcal{A}}$, $\mathbf{b} \in \Omega_{\mathcal{B}}$ and $\mathbf{c} \in \Omega_{\mathcal{C}}$ we have $\kappa(\mathbf{a}|\mathbf{bc}) = \kappa(\mathbf{a}|\mathbf{c})$.

Ordinal conditional functions imply an ordering \leq_{κ} on Ω , it is $\omega \leq_{\kappa} \omega'$ if and only if $\kappa(\omega) \leq \kappa(\omega')$ and likewise a strict ordering $<_{\kappa}$ on Ω , it is $\omega <_{\kappa} \omega'$ if and only if $\kappa(\omega) < \kappa(\omega')$. This gives rise to a nonmonotonic entailment relation defined as follows:

Definition 8 (κ -entailment [25,26]). Let κ be an OCF inducing a preference relation $<_{\kappa}$ on Ω . Let $\phi, \psi \in \mathcal{L}$. ϕ κ -entails ψ (written $\phi \vdash_{\kappa} \psi$) if and only if $\phi\psi$ is more plausible than $\phi\bar{\psi}$, formally

$$\phi \vdash_{\kappa} \psi \quad \text{if and only if} \quad \phi\psi <_{\kappa} \phi\bar{\psi} \quad \text{if and only if} \quad \kappa(\phi\psi) < \kappa(\phi\bar{\psi}).$$

The entailment of Definition 8 can equally be defined by preferential entailment as introduced in Section 2 (cf. [19]), that is, we can define κ -entailment equivalently by

$$\phi \vdash_{\kappa} \psi \quad \text{if and only if} \quad \text{for all } \omega' \models \phi\bar{\psi} \text{ exists a } \omega \models \phi\psi \text{ such that } \omega <_{\kappa} \omega'.$$

Ordinal conditional functions share many aspects of other numerical knowledge representation approaches like probabilistics, Dempster–Shafer belief functions, possibility theory and fuzzy logic (cf. [26, Chap. 10f] as well as [25,19,13, 12]). Since in this article we focus on comparing OCF-networks with CP-networks which rely on preference relations

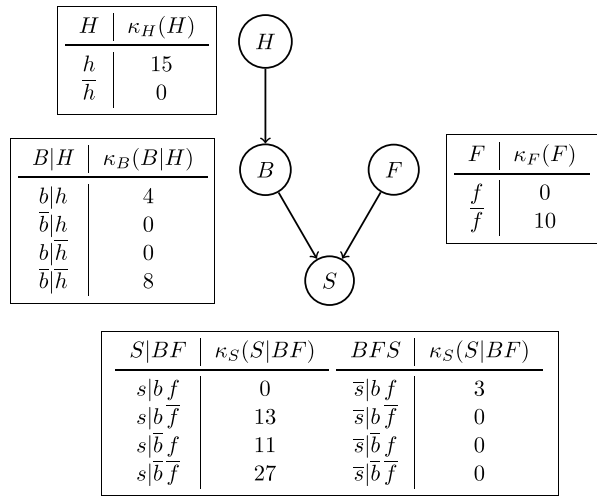

Fig. 2. OCF-network for the car-start example.

only, we omit a repetition of the formal properties of OCF not needed in this context and refer the interested reader to the mentioned literature. OCFs can be combined with directed acyclic graphs by annotating each vertex $V \in \Sigma$ with a conditional ranking table containing the conditional ranks of the outcomes of V given the outcomes of its parents as follows.

Definition 9 (OCF-network [10,15–18]). Let $\Gamma = \langle \Sigma, \mathcal{E}, \{\kappa_V\}_{V \in \Sigma} \rangle$ be a directed acyclic graph defined by a set of edges $E = (V, V') \in \mathcal{E}$ over the set of variables Σ where each vertex $V \in \Sigma$ is annotated with a local ranking table $\kappa_V(V|pa(V))$ of a vertex V in the context of its parents. Each ranking table is normalised, that is, there is an outcome \dot{v} of V for each configuration of the parent variables \mathbf{p}_V such that $\kappa_V(\dot{v}|\mathbf{p}_V) = 0$.

OCF-networks share crucial properties with Bayesian networks [23] as shown in [18]:

Factorisation An OCF-network induces a global ranking function

$$\kappa(\omega) = \sum_{V \in \Sigma} \kappa_V(V(\omega)|pa(V)(\omega)). \tag{2}$$

Local/global coincidence The global ranking function κ of an OCF-network Γ coincides with the local ranking tables on the respective marginals

$$\kappa(V(\omega)|pa(V)(\omega)) = \kappa_V(V(\omega)|pa(V)(\omega)). \tag{3}$$

Independence The global ranking function κ of an OCF-network Γ satisfies the local directed Markov Property, that is, each variable is independent from its non-descendants given its parents, formally

$$V \perp\!\!\!\perp_{\kappa} nd(V) \mid pa(V). \tag{4}$$

We illustrate OCF-networks with the following example.

Example 3. We illustrate OCF-networks and ranking entailment with the car-start example (confer [16,7]), modelling whether it is plausible that a car will start dependent on whether there is fuel in the fueltank and the battery is charged, which itself depends on the question whether the car’s headlights have been switched off overnight. We use a propositional alphabet $\Sigma = \{H, B, F, S\}$ where H stands for “headlights have been left on overnight” (h) or “headlights have been switched off overnight” (\bar{h}), B stands for “battery is charged” (b) or “battery is discharged” (\bar{b}), F stands for “fueltank is filled” (f) or “fueltank is empty” (\bar{f}), and S stands for “the car starts” (s) or “the car does not start” (\bar{s}). Fig. 2 shows an OCF-network for the car-start example, the global OCF of this network is given

Table 1
Global OCF for the OCF-network in Fig. 2.

ω	$hbfs$	$hb\bar{f}\bar{s}$	$h\bar{b}\bar{f}s$	$h\bar{b}\bar{f}\bar{s}$	$\bar{h}\bar{b}fs$	$\bar{h}\bar{b}\bar{f}\bar{s}$	$\bar{h}\bar{b}\bar{f}s$	$\bar{h}\bar{b}\bar{f}\bar{s}$
$\kappa_{\Gamma}(\omega)$	19	32	40	56	18	15	25	25
ω	$\bar{h}\bar{b}fs$	$\bar{h}\bar{b}\bar{f}\bar{s}$	$\bar{h}\bar{b}\bar{f}s$	$\bar{h}\bar{b}\bar{f}\bar{s}$	$\bar{h}\bar{b}fs$	$\bar{h}\bar{b}\bar{f}\bar{s}$	$\bar{h}\bar{b}\bar{f}s$	$\bar{h}\bar{b}\bar{f}\bar{s}$
$\kappa_{\Gamma}(\omega)$	0	13	21	37	11	8	18	18

in Table 1. In this example from left-on headlights we can entail that the car will usually not start: We have $h \vdash_{\sim \kappa} \bar{s}$ since $\kappa(h\bar{s}) = \min_{\omega \models h\bar{s}} \{\kappa(\omega)\} = \min\{\kappa(hb\bar{f}\bar{s}), \kappa(hb\bar{f}s), \kappa(h\bar{b}\bar{f}\bar{s}), \kappa(h\bar{b}\bar{f}s)\} = \min\{32, 56, 15, 25\} = 15$ is strictly smaller than $\kappa(hs) = \min_{\omega \models hs} \{\kappa(\omega)\} = \min\{\kappa(hbfs), \kappa(hb\bar{f}s), \kappa(h\bar{b}\bar{f}s), \kappa(h\bar{b}\bar{f}\bar{s})\} = \min\{19, 40, 18, 25\} = 18$.

5. Mutual generation of networks

In this section we present approaches to generate a CP-network from a given OCF-network and vice versa. We illustrate that plain approaches successfully generate a CP-network from an OCF-network and an OCF-network from a CP-network, but in either direction fail to ensure that the generated network allows for the same inferences as the original one. Based on these insights, we define a property of OCF-networks that ensures that the generated CP-network allows for the same inferences as the original OCF-network. For the other direction we define bottom-up induction of OCF-networks, a more sophisticated approach to generate an OCF-network from a CP-network which allows for the same inferences as the original CP-network.

When generating one of the networks from the other, we have to keep in mind that we transfer the formal graphical structure, only. By their underlying formalisms, both network types represent different types of knowledge:

CP-networks, with their underlying conditional preference relation, represent personal preferences of the agent, that is, what s/he likes or dislikes respectively prefers in a given context. OCF-networks, with their underlying ordinal conditional function represent what the agent regards as (im-)plausible in a given context. So we have one network approach that formalises the preferences and another that formalises the epistemic state of an agent.

Both types of information are fundamentally different – even if it is not impossible that the most preferred state of an agent is also the most plausible one, this usually is not the case but belongs to the realm of wishful thinking. Lotteries, results of sports events and (un-)healthy lifestyles are examples that in real-life scenarios, the most plausible result is just not the most preferred one.

But if we succeed in encoding one of the network approaches in the other, we can simulate one network type with the respective other, as long as we keep the semantical differences clearly in mind.

5.1. Plain approaches

In this section we show that from a certain subclass of OCF-networks, that is, OCF-networks without local indifference, a CP-network can be derived directly from the local ranking tables. After that we show how the local preferences of a CP-networks can be used to generate local ranking tables of an OCF-network sharing the same graphical structure.

In a CP-network, the configurations of local variables V are preferred locally with respect to the outcome of the parent variables $pa(V)$. This concept can be transferred to OCF-networks using local conditional ranking tables as follows:

Definition 10 (Local κ -preference). Let $\Gamma = \langle \Sigma, \mathcal{E}, \{\kappa_V\}_{V \in \Sigma} \rangle$ be an OCF-network. The local ranking tables $\kappa_V, V \in \Sigma$ generate a preference relation $\preceq_{\mathbf{p}_V}^{\kappa}$ on $\{v, \bar{v}\}$ such that $v \preceq_{\mathbf{p}_V}^{\kappa} \bar{v}$ if and only if $\kappa_V(v|\mathbf{p}_V) \leq \kappa_V(\bar{v}|\mathbf{p}_V)$. We define the strict variant of \preceq^{κ} as usual, that is $v \prec_{\mathbf{p}_V}^{\kappa} \bar{v}$ if and only if $v \preceq_{\mathbf{p}_V}^{\kappa} \bar{v}$ and $\bar{v} \not\preceq_{\mathbf{p}_V}^{\kappa} v$.

Our goal is to generate a CP-network from an OCF-network Γ , in the desired data structure the local information stored in the CPTs must be strict preferences. OCF-networks store local information as ranking tables which allow for indifference between local configurations, that is, in a local ranking table κ_V it is possible to have values $\kappa_V(v|\mathbf{p}) =$

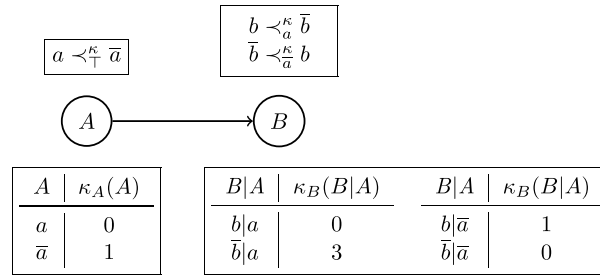

Fig. 3. OCF-network with induced CP-network of Example 4.

$\kappa_V(\bar{v}|\mathbf{p}) = 0$ and therefore \preceq^{κ} is not strict in general, whereas the local preferences $<$ in CP-networks must be strict relations. In the following we restrict OCF-networks to comply with the strict preference of CP-networks:

Definition 11 (Strict OCF-network). An OCF-network $\Gamma = \langle \Sigma, \mathcal{E}, \{\kappa_V\}_{V \in \Sigma} \rangle$ is called a *strict OCF-network* if and only if $\kappa_V(\dot{v}|\mathbf{p}_V) = 0$ implies $\kappa_V(\bar{v}|\mathbf{p}_V) \neq 0$ for all configurations \mathbf{p}_V of $pa(V)$ for all $V \in \Sigma$.

With the normalisation condition of OCFs, strict OCF-networks enforce that for each variable V either $\kappa(v|\mathbf{p}) = 0$ or $\kappa(\bar{v}|\mathbf{p}) = 0$ for every $\mathbf{p} \in \Omega_{pa(V)}$. Therefore in a strict OCF-network every local κ -preference is strict which we formalise in the following lemma.

Lemma 2. Let $\Gamma = \langle \Sigma, \mathcal{E}, \{\kappa_V\}_{V \in \Sigma} \rangle$ be a strict OCF-network. The local κ -preference on Γ by Definition 10 is strict, that is $\dot{v} \preceq_{\mathbf{p}_V}^{\kappa} \bar{v}$ implies $\bar{v} \not\preceq_{\mathbf{p}_V}^{\kappa} \dot{v}$ for all $V \in \Sigma$.

Proof. By reductio ad absurdum. Assume there would be a $V \in \Sigma$ with $\mathbf{p} \in \Omega_{pa(V)}$ such that $\dot{v} \preceq_{\mathbf{p}_V}^{\kappa} \bar{v}$ and $\bar{v} \preceq_{\mathbf{p}_V}^{\kappa} \dot{v}$. By Definition 10 this would imply $\kappa_V(\dot{v}|\mathbf{p}_V) \leq \kappa_V(\bar{v}|\mathbf{p}_V)$ and $\kappa_V(\bar{v}|\mathbf{p}_V) \leq \kappa_V(\dot{v}|\mathbf{p}_V)$ which is equivalent to $\kappa_V(\dot{v}|\mathbf{p}_V) = \kappa_V(\bar{v}|\mathbf{p}_V)$. By the normalisation condition this implies $\kappa_V(\dot{v}|\mathbf{p}_V) = \kappa_V(\bar{v}|\mathbf{p}_V) = 0$ in contradiction to Definition 11 of strict OCF-networks. Therefore in a strict OCF-network the local κ -preference $\preceq_{\mathbf{p}_V}^{\kappa}$ is strict for all $V \in \Sigma$. \square

Now we can define local κ -preference tables by using strict κ -preference as relation in conditional preference tables from Definition 1.

Definition 12 (Local κ -preference table). Let $\Gamma = \langle \Sigma, \mathcal{E}, \{\kappa_V\}_{V \in \Sigma} \rangle$ be a strict OCF-network. For every $V \in \Sigma$ the local κ -preference tables $CPT^{\kappa}(V, pa(V))$ express the local κ -preference $\preceq_{\mathbf{p}_V}^{\kappa}$ of the outcomes of V given each $\mathbf{p}_V \in \Omega_{pa(V)}$. In other words we have $\dot{v} \preceq_{\mathbf{p}_V}^{\kappa} \bar{v}$ if and only if $\kappa_V(\dot{v}|\mathbf{p}_V) < \kappa_V(\bar{v}|\mathbf{p}_V)$.

So we can find a common base for OCF- and CP-networks using networks with local (κ -)preference tables by focusing on strict OCF-networks where for each configuration \mathbf{p}_V in the ranking tables κ_V we obtain a conditional κ -preference $\preceq_{\mathbf{p}_V}^{\kappa}$.

Proposition 1. Let $\Gamma = \langle \Sigma, \mathcal{E}, \{\kappa_V\}_{V \in \Sigma} \rangle$ be a strict OCF-network with local κ -preference tables $CPT^{\kappa}(V, pa(V))$. Then $\Pi = \langle \Sigma, \mathcal{E}, \{CPT^{\kappa}(V, pa(V))\}_{V \in \Sigma} \rangle$ is a CP-network.

Proof. The graph structure of an OCF-network is a DAG, identically to the structure for CP-networks. In this graph, every vertex $V \in \Sigma$ is annotated with a strict $CPT^{\kappa}(V, pa(V))$ according to Definition 1. Therefore $\Pi = \langle \Sigma, \mathcal{E}, \{CPT^{\kappa}(V, pa(V))\}_{V \in \Sigma} \rangle$ is a CP-network as proposed. \square

We illustrate this proposition with the following example.

Example 4. Let $\Sigma = \{A, B\}$ be a propositional alphabet. Let $(\Sigma, \{(A, B)\})$ be a DAG on Σ with local ranking tables given in Fig. 3 (lower part). It is clear that the OCF-network $\Gamma = \langle \Sigma, \{(A, B)\}, \{\kappa_A, \kappa_B\} \rangle$ is a strict

Table 2
Global OCF for OCF-network of Fig. 3.

ω	ab	$a\bar{b}$	$\bar{a}b$	$\bar{a}\bar{b}$
$\kappa(\omega)$	0	3	2	1

OCF-network. From κ_A and κ_B we derive the local preferences $a \prec_{\top}^{\kappa} \bar{a}$, $b \prec_a^{\kappa} \bar{b}$ and $\bar{b} \prec_{\bar{a}}^{\kappa} b$ which define the local κ -preference tables $CPT^{\kappa}(A, \emptyset)$ and $CPT^{\kappa}(B, \{A\})$ as given in Fig. 3 (upper part) to obtain the CP-network $\Pi = \langle \Sigma, \{(A, B)\}, \{CPT_A^{\kappa}, CPT_B^{\kappa}\} \rangle$.

By Proposition 1 we obtained that we can derive a CP-network from a strict OCF-network directly from the local ranking tables, as proposed. Nonetheless the networks are not identical with respect to their inferences, which we formalise with the following observation.

Observation 1. *There are strict OCF-networks $\Gamma = \langle \Sigma, \mathcal{E}, \{\kappa_V\}_{V \in \Sigma} \rangle$ such that for the induced CP-networks $\Pi = \langle \Sigma, \mathcal{E}, \{CPT^{\kappa}(V, pa(V))\}_{V \in \Sigma} \rangle$ there are formulas $\phi, \psi \in \mathcal{L}$ such that $\phi \vdash_{\kappa} \psi$ but $\phi \not\vdash_{\Pi} \psi$.*

The OCF-network of Fig. 3 provides a global OCF κ that is shown in Table 2. Here from \bar{b} we can κ -entail \bar{a} , that is, we have $\bar{b} \vdash_{\kappa} \bar{a}$ since $\kappa(\bar{a}\bar{b}) = 1 < 3 = \kappa(a\bar{b})$. The CP-network derived from this OCF-network possesses exactly one preference relation that satisfies the network which is $ab \prec_{cp} \bar{a}\bar{b} \prec_{cp} \bar{a}b \prec_{cp} \bar{a}\bar{b}$ which implies $\prec_{cp} = \prec_{\Pi}$. Here we have $\bar{a}\bar{b} \prec_{\Pi} \bar{a}b$ and hence $\bar{b} \not\vdash_{\Pi} \bar{a}$ according to Definition 4, so we see that there are indeed strict OCF-networks whose inference properties are not preserved in the induced CP-network, as proposed in Observation 1.

So we see that even if the generated structure formally is a CP-network, the stored information is different from the information in the OCF-network with respect to inferred propositions. We return to this issue in Section 5.2 where we define a subclass of strict OCF-networks which allows for the same inferences as the derived CP-network.

After we plainly generated CP-networks from OCF-networks, we now concentrate on the opposite direction and generate OCF-networks from CP-networks with respect to the CPTs directly.

Proposition 2. *Let $\Pi = \langle \Sigma, \mathcal{E}, \{CPT(V, pa(V))\}_{V \in \Sigma} \rangle$ be a CP-network. Π induces a strict OCF-network $\Gamma = \langle \Sigma, \mathcal{E}, \{\kappa_V\}_{V \in \Sigma} \rangle$ on Σ such that for every $V \in \Sigma$ and every configuration \mathbf{p}_V of $pa(V)$ the preference $\bar{v} \prec_{\mathbf{p}_V} v$ in $CPT(V, pa(V))$ implies that $\kappa_V(\bar{v}|\mathbf{p}_V) = 0$ and $\kappa_V(v|\mathbf{p}_V) = 1$.*

Proof. We show that $\Gamma = \langle \Sigma, \mathcal{E}, \{\kappa_V\}_{V \in \Sigma} \rangle$ as specified in Proposition 2 is a strict OCF-network. By definition of CP-networks, (Σ, \mathcal{E}) is a DAG, which is necessary for an OCF-network. The possible local ranking values are $\{0, 1\} \subseteq \mathbb{N}_0$, hence the tables $\{\kappa_V\}_{V \in \Sigma}$ have a range of values that is valid for OCFs. For each $V \in \Sigma$ and each interpretation \mathbf{p}_V of $pa(V)$ in a CP-network we either have $\bar{v} \prec_{\mathbf{p}_V} v$ or $v \prec_{\mathbf{p}_V} \bar{v}$, therefore either $\kappa_V(v|\mathbf{p}_V) = 0$ or $\kappa_V(\bar{v}|\mathbf{p}_V) = 0$ and the local ranking tables are normalised. Therefore, $\Gamma = \langle \Sigma, \mathcal{E}, \{\kappa_V\}_{V \in \Sigma} \rangle$ is an OCF-network. Since for each V we either have $\kappa_V(v|\mathbf{p}_V) = 0$ or $\kappa_V(\bar{v}|\mathbf{p}_V) = 0$ and never both, the OCF-network is strict. \square

We illustrate this generation procedure with the following example.

Example 5. Let $\Sigma = \{A, B, C\}$ and $(\Sigma, \{(A, B), (B, C)\})$ be a DAG on Σ with conditional preference tables as given in Fig. 4 (lower part). With Proposition 2 we obtain $\kappa_A(a) = 0$ and $\kappa_A(\bar{a}) = 1$ since $a \prec_{\top} \bar{a}$. We similarly obtain $\kappa_B(b|a) = 0$ and $\kappa_B(\bar{b}|a) = 1$ because $b \prec_a \bar{b}$, $\kappa_B(\bar{b}|\bar{a}) = 0$ and $\kappa_B(b|\bar{a}) = 1$ because $\bar{b} \prec_{\bar{a}} b$ as well as $\kappa_C(c|b) = 0$ and $\kappa_C(\bar{c}|b) = 1$ because $c \prec_b \bar{c}$, $\kappa_C(\bar{c}|\bar{b}) = 0$ and $\kappa_C(c|\bar{b}) = 1$ because $\bar{c} \prec_{\bar{b}} c$, and therefore we get the local ranking tables given in Fig. 4 (upper part). It is clear that $\langle \Sigma, \{(A, B), (B, C)\}, \{\kappa_A, \kappa_B, \kappa_C\} \rangle$ is a strict OCF-network.

Like for CP-networks generated from OCF-networks, the inferences that can be drawn from an OCF-network generated from a CP-network are different in general from the inferences that can be drawn from the original network, as well, which we formalise in the following observation.

Observation 2. *There are CP-networks $\Pi = \langle \Sigma, \mathcal{E}, \{CPT(V, pa(V))\}_{V \in \Sigma} \rangle$ such that for the induced OCF-networks $\Gamma = \langle \Sigma, \mathcal{E}, \{\kappa_V\}_{V \in \Sigma} \rangle$ there are formulas $\phi, \psi \in \mathcal{L}$ such that $\phi \vdash_{\Pi} \psi$ but $\phi \not\vdash_{\Gamma} \psi$.*

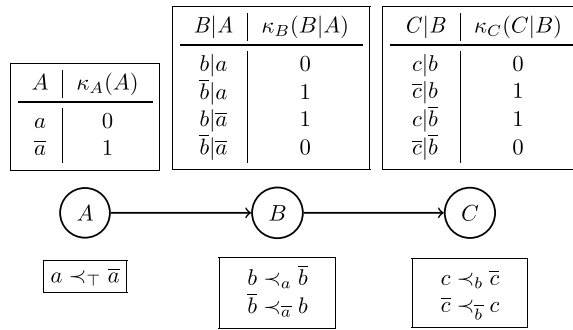

Fig. 4. CP-network with induced OCF-network of Example 5.

Table 3
Global OCF for the OCF-network of Example 5.

ω	abc	$ab\bar{c}$	$a\bar{b}c$	$a\bar{b}\bar{c}$	$\bar{a}bc$	$\bar{a}b\bar{c}$	$\bar{a}\bar{b}c$	$\bar{a}\bar{b}\bar{c}$
$\kappa(\omega)$	0	1	1	1	2	3	2	2

The CP-network from Example 5 is a CP-network as described in Observation 2. Here, there are two relations that satisfy the CP-network from Example 5, these are

$$\begin{aligned}
 abc &<_{cp}^{(1)} ab\bar{c} <_{cp}^{(1)} a\bar{b}\bar{c} <_{cp}^{(1)} \underline{a\bar{b}c} <_{cp}^{(1)} \underline{a\bar{b}\bar{c}} <_{cp}^{(1)} \bar{a}\bar{b}c <_{cp}^{(1)} \bar{a}bc <_{cp}^{(1)} \bar{a}b\bar{c} \\
 abc &<_{cp}^{(2)} ab\bar{c} <_{cp}^{(2)} a\bar{b}\bar{c} <_{cp}^{(2)} \underline{a\bar{b}\bar{c}} <_{cp}^{(2)} \underline{a\bar{b}c} <_{cp}^{(2)} \bar{a}\bar{b}c <_{cp}^{(2)} \bar{a}bc <_{cp}^{(2)} \bar{a}b\bar{c}
 \end{aligned}$$

and so we have $\bar{c} \sim_{cp} b$ because $ab\bar{c}$ is cp-preferred both to $a\bar{b}\bar{c}$ and $\bar{a}\bar{b}\bar{c}$. The generated OCF-network induces the global ranking function shown in Table 3 and here we find $\kappa(b\bar{c}) = 1 = \kappa(\bar{b}\bar{c})$ and therefore $\bar{c} \not\prec_{\kappa} b$ which proves Observation 2.

So even if we can derive a valid OCF-network from a CP-network, the networks are not identical with respect to inference. This failure of not preserving the (global) inference properties of either network type in the process of generating the respective other results from the plain approach just taking local information into account, whilst certain properties – like, for instance, (conditional) independence and inference – are global properties. As we have seen, these properties need a more sophisticated approach to be transferred properly. Nonetheless the insights gained by setting up and analysing the plain approach will be vital building blocks when we, in the following, address these two issues in mutual generation by further restricting OCF-networks used to generate CP-networks and refine the process of setting local ranks to an OCF-network from the CPTs of a CP-network algorithmically.

5.2. Bottom-up induction of OCF-networks

In the previous section we have seen that the plain approaches that just take local information into account fail to ensure that the respective generated network allows for the same (global) entailments as the original one. One major reason for this is that the global preference relation of a CP-network is the sceptical combination of all preference relations that satisfy the network, whereas the global ranking function and thus the ranking preference is obtained by the factorisation property (2). The latter does not necessarily generate a preference relation that coincides with the global preference relation of a CP-network, which we formalise in the following observation.

Observation 3. *There are strict OCF-networks $\Gamma = \langle \Sigma, \mathcal{E}, \{\kappa_V\}_{V \in \Sigma} \rangle$ with a global OCF κ that induces a relation $<_{\kappa}$ on Ω which does not satisfy the local preference relations $<_{\mathbf{p}}^{\kappa}$.*

Example 4 with the global OCF κ given in Table 2 provides such an OCF-network: If $<_{\kappa}$ would satisfy the local preference relations $<_{\mathbf{p}}^{\kappa}$, we would have $a\bar{b} <_{\kappa} \bar{a}b$ for each interpretation \bar{b} of B which is required to satisfy $a <_{\top}^{\kappa} \bar{a}$. But since $\kappa(a\bar{b}) = 3 > 1 = \kappa(\bar{a}b)$ we actually have $a\bar{b} \not\prec_{\kappa} \bar{a}b$ which does not satisfy $a <_{\top}^{\kappa} \bar{a}$.

By the above observation we obtain that the global relation $<_{\kappa}$ of an OCF-network does not satisfy the satisfiability condition of CP-networks in general. If we generate a CP-network Π from an OCF-network, the global relation $<_{\Pi}$ satisfies this condition for all local preferences by [Definition 3](#). Hence $<_{\kappa}$ and $<_{\Pi}$ are different in general. The same occurs for the mirrored case of an OCF-network generated from a CP-network.

Observation 4. Let Π be a CP-network. Let Γ be the strict OCF-network generated from Π according to [Proposition 2](#). The relation $<_{\kappa}$ on the set of possible worlds induced by the global OCF κ of Γ according to the factorisation property (2) is different from the relation $<_{\Pi}$ on Π in general.

[Example 5](#) with the local preferences and local OCFs given in [Fig. 4](#) and the global OCF κ given in [Table 3](#) is an example to support [Observation 4](#). Here, we have the local preference $b <_a \bar{b}$ hence the satisfiability condition for Π requires that we globally have $abc <_{\Pi} a\bar{b}\bar{c}$ for all fixed outcomes \bar{c} of C , especially $ab\bar{c} <_{\Pi} a\bar{b}\bar{c}$. In the global OCF of this example ([Table 3](#)) we have $\kappa(ab\bar{c}) = 1 = \kappa(a\bar{b}\bar{c})$, hence $ab\bar{c} \not<_{\kappa} a\bar{b}\bar{c}$ but $ab\bar{c} <_{\Pi} a\bar{b}\bar{c}$. Overall we obtain that the plain generation according to the [Propositions 1 and 2](#) generates the designated structures, but fails to guarantee that the global preferences and by this the inferences from the networks are identical.

We define the following property for ranking functions that ensures that the relation $<_{\kappa}$ of an OCF satisfies the local preferences $<^{\kappa}$ and hence the CPTs of a CP-network.

Definition 13 (Π -compatibility). Let Ω be a set of worlds over an alphabet Σ , let κ be an OCF $\kappa : \Omega \rightarrow \mathbb{N}_0$, let Π be a CP-network over Σ . κ is compatible to Π if and only if for all $\omega, \omega' \in \Omega$ the global preference $\omega <_{\Pi} \omega'$ implies $\omega <_{\kappa} \omega'$.

Theorem 1. The global ranking function of a strict OCF-network $\Gamma = \langle \Sigma, \mathcal{E}, \{\kappa_V\}_{V \in \Sigma} \rangle$ is compatible to the CP-network $\Pi = \langle \Sigma, \mathcal{E}, \{CPT(V, pa(V))\}_{V \in \Sigma} \rangle$ generated from Γ by [Proposition 1](#) if for all local ranking tables $\kappa_V(V|pa(V))$, it holds that

$$\max_{\dot{v} \in \{v, \bar{v}\}} \{\kappa_V(\dot{v}|\mathbf{p}_V)\} > \sum_{C \in ch(V)} \left[\begin{array}{c} \max_{\dot{c} \in \{c, \bar{c}\}} \\ \mathbf{p}_C \in \Omega_{pa(C)} \end{array} \right] \{\kappa_C(\dot{c}|\mathbf{p}_C)\} \tag{5}$$

for every $V \in \Sigma$ and $\mathbf{p}_V \in \Omega_{pa(V)}$.

Π -compatibility ensures that the preferences induced on the possible worlds by the global ranking function implement the preferences induced by the global CP-network. Since both global functions are composed from the local information stored in the graph, this property has to be realised by the local representations (rankings as well as CPTs). [Theorem 1](#) ensures that this can be achieved by constraining the local conditional ranks of each vertex $V \in \Sigma$ by the combination of the ranks of the children of V : We recall that for each vertex $V \in \Sigma$ we have $\min_{\dot{v} \in \{v, \bar{v}\}} \{\kappa_V(\dot{v}|\mathbf{p}_V)\} = 0$ because of the normalisation condition of OCFs (cf. [Definition 6](#)), whereas the most implausible outcome, $\max_{\dot{v} \in \{v, \bar{v}\}} \{\kappa_V(\dot{v}|\mathbf{p}_V)\}$, of V in the context of the outcomes \mathbf{p}_V of the parents of V is a (semi-)positive integer. Inequality (5) ensures that the most implausible outcome of each V given \mathbf{p}_V is strictly more implausible than the sum of the most implausible outcomes of the childrens of V (or at least 1 if V is a leaf).

Proof. Let $\Gamma = \langle \Sigma, \mathcal{E}, \{\kappa_V\}_{V \in \Sigma} \rangle$ be an OCF-network with a global OCF κ . For Γ we have the local preferences $<_{\mathbf{p}}^{\kappa}$ for every $V \in \Sigma$ and every $\mathbf{p} \in \Omega_{pa(V)}$ which result in preference tables $CPT^{\kappa}(V, pa(V))$ according to [Definitions 10 and 12](#). Let $\Pi = \langle \Sigma, \mathcal{E}, \{CPT^{\kappa}(V, pa(V))\}_{V \in \Sigma} \rangle$ be the CP-network generated from Γ according to [Proposition 1](#). Then we have $\kappa_V(\dot{v}|\mathbf{p}) < \kappa_V(\bar{v}|\mathbf{p})$ if and only if $\dot{v} <_{\mathbf{p}}^{\kappa} \bar{v}$ if and only if $\dot{v} <_{\Pi} \bar{v}$.

In the first step of the proof we show that for every $V \in \Sigma$, every fixed $\mathbf{p} \in \Omega_{pa(V)}$ and every outcome \mathbf{r} of the variables of $\Sigma \setminus (\{V\} \cup pa(V))$ the local preference $\kappa_V(\dot{v}|\mathbf{p}) < \kappa_V(\bar{v}|\mathbf{p})$ implies $\kappa(\dot{v}\mathbf{pr}) < \kappa(\bar{v}\mathbf{pr})$ given (5).

So let $\kappa_V(\dot{v}|\mathbf{p}) < \kappa_V(\bar{v}|\mathbf{p})$ and (5) hold, we show $\kappa(\dot{v}\mathbf{pr}) < \kappa(\bar{v}\mathbf{pr})$. In order to do so, we separate the outcome \mathbf{c} of $ch(V)$ from \mathbf{r} such that $\mathbf{c}\mathbf{o} = \mathbf{r}$ and inspect the left-hand side of the inequality under consideration, that is $\kappa(\dot{v}\mathbf{p}\mathbf{c}\mathbf{o})$, first. Here, (2) gives us

$$\kappa(\dot{v}\mathbf{p}\mathbf{c}\mathbf{o}) = \sum_{W \in \Sigma} \kappa_W(W(\dot{v}\mathbf{p}\mathbf{c}\mathbf{o})|pa(W)(\dot{v}\mathbf{p}\mathbf{c}\mathbf{o})).$$

We separate κ_V from the sum and further split up the remaining sum into the sum over the children of V and the rest of the variables, obtaining

$$\begin{aligned} \kappa(\dot{\mathbf{v}}\mathbf{pco}) &= \kappa_V(V(\dot{\mathbf{v}}\mathbf{pco})|pa(V)(\dot{\mathbf{v}}\mathbf{pco})) + \sum_{W \in ch(V)} \kappa_W(W(\dot{\mathbf{v}}\mathbf{pco})|pa(W)(\dot{\mathbf{v}}\mathbf{pco})) \\ &+ \sum_{W \in \Sigma \setminus (\{V\} \cup ch(V))} \kappa_W(W(\dot{\mathbf{v}}\mathbf{pco})|pa(W)(\dot{\mathbf{v}}\mathbf{pco})). \end{aligned}$$

For variables in $\Sigma \setminus (\{V\} \cup ch(V))$, V does not appear in the local ranking tables, therefore we have

$$\begin{aligned} \kappa(\dot{\mathbf{v}}\mathbf{pco}) &= \kappa_V(V(\dot{\mathbf{v}}\mathbf{pco})|pa(V)(\dot{\mathbf{v}}\mathbf{pco})) + \sum_{W \in ch(V)} \kappa_W(W(\dot{\mathbf{v}}\mathbf{pco})|pa(W)(\dot{\mathbf{v}}\mathbf{pco})) \\ &+ \underbrace{\sum_{W \in \Sigma \setminus (\{V\} \cup ch(V))} \kappa_W(W(\mathbf{pco})|pa(W)(\mathbf{pco}))}_{(I)}. \end{aligned}$$

We presupposed \mathbf{pco} to be fixed and V does not appear in (I) , therefore (I) is a constant summand for $\kappa(\dot{\mathbf{v}}\mathbf{pco})$. Furthermore, $\kappa_V(V(\dot{\mathbf{v}}\mathbf{pco})|pa(V)(\dot{\mathbf{v}}\mathbf{pco}))$ is evaluated to $\kappa_V(\dot{\mathbf{v}}|\mathbf{p})$. So overall we obtain

$$\kappa(\dot{\mathbf{v}}\mathbf{pco}) = \kappa_V(\dot{\mathbf{v}}|\mathbf{p}) + \underbrace{\sum_{W \in ch(V)} \kappa_W(W(\dot{\mathbf{v}}\mathbf{pco})|pa(W)(\dot{\mathbf{v}}\mathbf{pco}))}_{(II)} + (I).$$

The same argumentation applies to the right hand side of the inequality under consideration, so for this we obtain

$$\kappa(\bar{\mathbf{v}}\mathbf{pco}) = \kappa_V(\bar{\mathbf{v}}|\mathbf{p}) + \underbrace{\sum_{W \in ch(V)} \kappa_W(W(\bar{\mathbf{v}}\mathbf{pco})|pa(W)(\bar{\mathbf{v}}\mathbf{pco}))}_{(III)} + (I).$$

By prerequisite we have $\kappa_V(\dot{\mathbf{v}}|\mathbf{p}) < \kappa_V(\bar{\mathbf{v}}|\mathbf{p})$. With the normalisation condition of ranking functions this implies $\kappa_V(\dot{\mathbf{v}}|\mathbf{p}) = 0$, so the inequality $\kappa(\dot{\mathbf{v}}\mathbf{pco}) < \kappa(\bar{\mathbf{v}}\mathbf{pco})$ is equivalent to

$$(I) + (II) < \kappa_V(\bar{\mathbf{v}}|\mathbf{p}) + (I) + (III)$$

and therefore we have to prove $(II) < \kappa_V(\bar{\mathbf{v}}|\mathbf{p}) + (III)$. Together with (5) the prerequisite $\kappa_V(\dot{\mathbf{v}}|\mathbf{p}) < \kappa_V(\bar{\mathbf{v}}|\mathbf{p})$ gives us

$$\kappa_V(\bar{\mathbf{v}}|\mathbf{p}) > \sum_{C \in ch(V)} \max_{\substack{\dot{c} \in \{c, \bar{c}\}, \\ \mathbf{p}_C \in \Omega_{pa(C)}}} \{\kappa_C(\dot{c}|\mathbf{p}_C)\}$$

which implies $\kappa_V(\bar{\mathbf{v}}|\mathbf{p}) > (II)$. Since the codomain of κ is $\mathbb{N}_0 \cup \{\infty\}$, (III) cannot be smaller than 0 and therefore from $\kappa_V(\dot{\mathbf{v}}|\mathbf{p}) < \kappa_V(\bar{\mathbf{v}}|\mathbf{p})$ we have $\kappa(\dot{\mathbf{v}}\mathbf{pco}) < \kappa(\bar{\mathbf{v}}\mathbf{pco})$ under (5), as proposed.

With this we now proceed to the second step: Since $<_{\Pi}$ is determined by comparing worlds ω, ω' of the form $\omega = \dot{\mathbf{v}}\mathbf{pco}$ and $\omega' = \bar{\mathbf{v}}\mathbf{pco}$, it is enough to prove the compatibility of κ to Π for such worlds. So let $\omega = \dot{\mathbf{v}}\mathbf{pco} <_{\Pi} \bar{\mathbf{v}}\mathbf{pco} = \omega'$. Then for all Π -satisfying relations $<_{cp}$, we have $\dot{\mathbf{v}}\mathbf{pco} <_{cp} \bar{\mathbf{v}}\mathbf{pco}$ which holds iff $\dot{\mathbf{v}} <_{\mathbf{p}} \bar{\mathbf{v}}$. By construction of Π , this means $\kappa_V(\dot{\mathbf{v}}|\mathbf{p}) < \kappa_V(\bar{\mathbf{v}}|\mathbf{p})$. From the first step, this implies $\kappa(\dot{\mathbf{v}}\mathbf{pco}) < \kappa(\bar{\mathbf{v}}\mathbf{pco})$, i.e., $\kappa(\omega) < \kappa(\omega')$, and so $\omega <_{\kappa} \omega'$. Fig. 5 illustrates this step of the proof. \square

In the following, an OCF-network the global OCF of which is compatible to a CP-network Π according to Definition 13 is called a Π -compatible OCF-network. From Theorem 1 and the definition of the nonmonotonic entailment relations based on preferential models we directly obtain:

Corollary 1. *Let Γ be an OCF-network with a nonmonotonic entailment relation \vdash_{κ} . Let Π be the generated CP-network from Γ according to Proposition 1 such that (5) holds with a nonmonotonic entailment relation \vdash_{Π} . Then we have $\phi \vdash_{\kappa} \psi$ if $\phi \vdash_{\Pi} \psi$.*

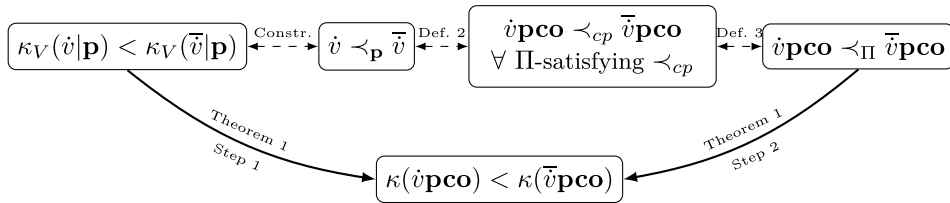

Fig. 5. Structure of proof for Theorem 1.

With Corollary 1 we can derive CP-networks from a subclass of OCF-networks such that their inferences are at least compatible, i.e., the \vdash_{Π} -inferences are contained in the \vdash_{κ} -inferences. In the following we show the opposite direction, that is, we present an algorithm to derive an OCF-network from a CP-network that is compatible to the original network.

Algorithm 1.

Input: CP-network $\Pi = \langle \Sigma, \mathcal{E}, \{CPT(V, pa(V))\}_{V \in \Sigma} \rangle$

Output: strict OCF-network $\Gamma = \langle \Sigma, \mathcal{E}, \{\kappa_V\}_{V \in \Sigma} \rangle$ compatible to Π

We traverse through Σ in reverse breadth-first ordering with respect to (Σ, \mathcal{E}) that is we start with the vertices without children, continue with the parents of these vertices and then continue with the parents of the parents, recursively, setting the local ranking values step by step. So let $\Sigma = \{V_1, \dots, V_n\}$ be enumerated such that for each $V_i \in \Sigma$ we have $pa(V_i) \subseteq \{V_1, \dots, V_{i-1}\}$.

- Traverse through Σ from n to 1 in descending order.
- If V_i has no outgoing edges, that is, $ch(V_i) = \emptyset$, assign $\kappa_{V_i}(\psi_i | \mathbf{p}_{V_i}) = 0$ if $\psi_i <_{\mathbf{p}_{V_i}} \bar{\psi}_i$ and $\kappa_{V_i}(\psi_i | \mathbf{p}_{V_i}) = 1$, otherwise for every configuration $\mathbf{p}_{V_i} \in \Omega_{pa(V_i)}$.
- For each other vertex $V_i \in \Sigma$ with $ch(V) \neq \emptyset$ and each $\mathbf{p}_{V_i} \in \Omega_{pa(V_i)}$, we set $\kappa_{V_i}(V | pa(V))$ to 0 for the preferred outcome of V given \mathbf{p} , and to the sum of the maximum ranks of the children of V plus 1 for the non-preferred one:

$$\kappa_{V_i}(\psi_i | \mathbf{p}_{V_i}) = \begin{cases} 0 & \text{if } \psi_i <_{\mathbf{p}_{V_i}} \bar{\psi}_i \\ \sum_{C \in ch(V)} \max_{\substack{c \in \{c, \bar{c}\}, \\ \mathbf{p}_C \in \Omega_{pa(C)}}} \{\kappa_C(c | \mathbf{p}_C)\} + 1 & \text{otherwise} \end{cases} \tag{6}$$

Note that this algorithm sets the rank of the non-preferred outcome of the vertices V without children to 1 for each outcome of the parent vertices, respectively, the rank of the non-preferred outcome of the parents V' of these vertices is set to $|ch(V)| + 1$ – for any other vertex, (6) has to be calculated individually.

It is clear that Algorithm 1 generates a CP-compatible OCF-network because for the leaves it generates strict local ranking tables that ensure that the local preference table is carried over to the ranking case, whereas for vertices that are no leaves it ensures that (5) holds by adding 1 to the sum of maximum ranks given in the ranking tables of the child vertices. The algorithm traverses Σ exactly once which ensures that it terminates. So by Theorem 1 we obtain that an OCF-network generated by Algorithm 1 is compatible to the original CP-network. This is summarised in the following theorem:

Theorem 2. Let Π be a CP-network. The OCF-network Γ obtained from Π by Algorithm 1 is compatible to Π .

We illustrate this algorithm with the following example:

Example 6. Let Π be the CP-network over $\Sigma = \{A, B, D, C, E, F\}$ given in Fig. 6. Starting at the leaves of the DAG we set κ_D, κ_E and κ_F according to Algorithm 1. In the reverse breadth-first order the next vertex to process is C , here we obtain $\kappa_C(c|a) = \kappa_C(\bar{c}|\bar{a}) = 0$ since $c <_a \bar{c}$ and $\bar{c} <_{\bar{a}} c$. The sum of the maximum ranking values in the table of the children of C is 3, therefore we set $\kappa_C(\bar{c}|a) = \kappa_C(c|\bar{a}) = 4$. We continue with B and set $\kappa_B(b|a) = \kappa_B(\bar{b}|\bar{a}) = 0$.

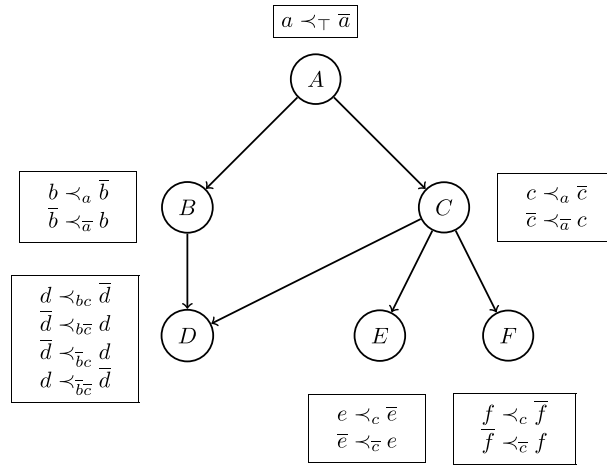

Fig. 6. CP-network of Example 6.

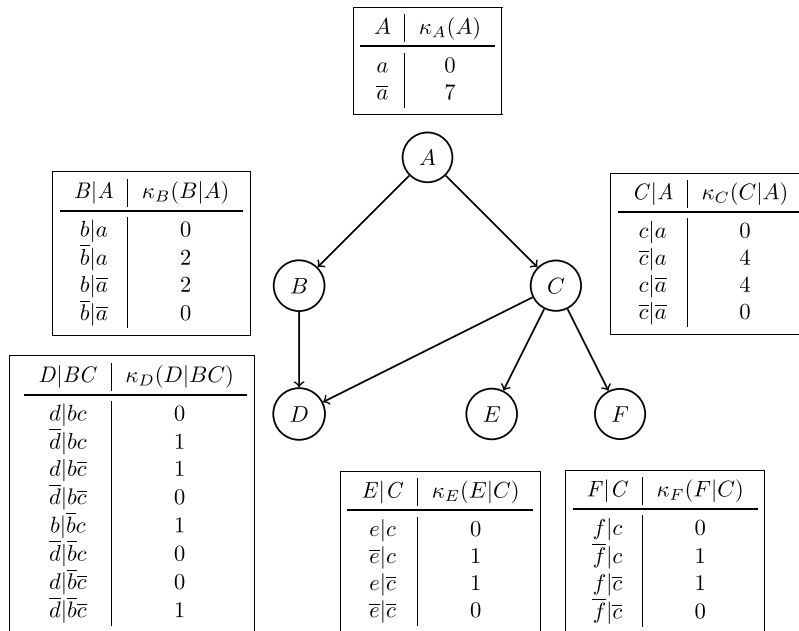

Fig. 7. Bottom-up induced OCF-network from the CP-network in Fig. 6.

Since B has only one child, according to the algorithm we obtain $\kappa_B(\bar{b}|a) = \kappa_B(b|\bar{a}) = 2$. The last vertex to process is A, here we have $\kappa_A(a) = 0$ directly from the CPT. The maximum ranks in the tables of the children of A are 2 for B and 4 for C, therefore we finally set $\kappa_A(\bar{a}) = 7$. Fig. 7 shows the generated OCF-network.

We return to the Examples 4 and 5 of Observations 1 and 2. For Observation 1 and Example 4 we see that the OCF presented there does not satisfy condition (5), because this would require that $\max\{\kappa_A(a), \kappa_A(\bar{a})\} = 1$ would be strictly greater than $\max\{\kappa_B(b|a), \kappa_B(\bar{b}|a), \kappa_B(b|\bar{a}), \kappa_B(\bar{b}|\bar{a})\} = 3$. Therefore neither Theorem 1 nor Algorithm 1 are applicable to this OCF-network. For Observation 2 the ranking tables $\kappa'_A, \kappa'_B, \kappa'_C$ of Example 5 generated with Algorithm 1 are the ones presented in Table 4, which result in the global OCF κ' also given in the table.

$$abc \prec_{\Pi} ab\bar{c} \prec_{\Pi} a\bar{b}\bar{c} \prec_{\Pi} \{a\bar{b}c, \bar{a}\bar{b}\bar{c}\} \prec_{\Pi} \bar{a}\bar{b}c \prec_{\Pi} \bar{a}bc \prec_{\Pi} \bar{a}b\bar{c}$$

$$abc \prec_{\kappa'_\Gamma} ab\bar{c} \prec_{\kappa'_\Gamma} a\bar{b}\bar{c} \prec_{\kappa'_\Gamma} \{a\bar{b}c, \bar{a}\bar{b}\bar{c}\} \prec_{\kappa'_\Gamma} \bar{a}\bar{b}c \prec_{\kappa'_\Gamma} \bar{a}bc \prec_{\kappa'_\Gamma} \bar{a}b\bar{c}$$

From Theorem 2 and the review of these examples we obtain:

Table 4
Local ranking tables and global ranking functions for Example 5 using Algorithm 1.

ω	abc	$ab\bar{c}$	$a\bar{b}c$	$a\bar{b}\bar{c}$	$\bar{a}bc$	$\bar{a}b\bar{c}$	$\bar{a}\bar{b}c$	$\bar{a}\bar{b}\bar{c}$
$\kappa'_A(A(\omega))$	0	0	0	0	3	3	3	3
$\kappa'_B(B(\omega) A(\omega))$	0	0	2	2	2	2	0	0
$\kappa'_C(C(\omega) B(\omega))$	0	1	1	0	0	1	1	0
$\kappa'(\omega)$	0	1	3	2	5	6	4	3

Corollary 2. *There is a compatible OCF-network to every CP-network, the reverse is not true in general, that is, there are OCF-networks $\Gamma = \langle \Sigma, \mathcal{E}, \{\kappa_V\}_{V \in \Sigma} \rangle$ for which no CP-network $\Pi = \langle \Sigma, \mathcal{E}, \{CPT(V, pa(V))\}_{V \in \Sigma} \rangle$ exists such that Γ is compatible to Π .*

6. Comparison of the two approaches

In the previous section we have shown that it is possible to generate one of the examined networks from the other, and vice versa. In this section we compare the formalisms of CP-networks and OCF-networks from the basic definitions in Sections 3 and 4 up to the results of Section 5.

Starting from the very basic definitions, ordinal conditional functions allow for two local configurations to be of identical rank, that is, we are able to express indifference with respect to a variable in a certain context of its parents. This is not possible in CP-networks where the CPTs are strict preferences between the different states of variables given a parent configuration. If the local representations are set by an expert, CPTs therefore implement a “forced choice” between the options, whereas OCF-networks allow for an expert to be undecided between the options. When setting the preferences or rankings from observations, from knowledge bases or by data mining (cf. [20,18,26] for techniques used for ranking functions and OCF-networks) this forced choice becomes problematic because there may be instances that are unobserved, not in the database or not covered by rules in the knowledge base. In this case, a CP-network cannot be set upon the data without setting preferences arbitrarily, bearing the risk of making the wrong choice. This could be overcome by extending CP-networks and allowing indifferences in the CTPs, replacing the relation $\prec_{\mathbf{p}}$ by a relation $\preceq_{\mathbf{p}}$ where $\dot{v} \preceq_{\mathbf{p}} \bar{v}$ and $\bar{v} \preceq_{\mathbf{p}} \dot{v}$ hold if we are indifferent with respect to V in the context of $\mathbf{p} \in \Omega_{pa(V)}$. Ref. [9] has shown that introducing indifference renders even simple CP-networks unsatisfiable, this change in the basic relation is therefore not a trivial intervention, an analysis whether the findings of Section 5 can be transferred to CP-networks with indifference is left for further work.

As noted, indifference on the level of local CPTs is a problematic intervention to CP-networks. This is not the case for the global CP-network preference \prec_{Π} . Since this relation is the intersection of all preference relations that satisfy the network, the relation is, in general, not total and there are sets of possible worlds which share the same (set of) preceding and succeeding worlds with respect to \prec_{Π} . This is identical for ranking preference \prec_{κ} , and so for each \prec_{Π} there is a \prec_{κ} with the same properties and hence \prec_{Π} is a schema for Π -satisfying global OCFs.

Corollary 3. *Let Π be a CP-network with a global preference \prec_{Π} . There are ranking functions κ such that for the relation \prec_{κ} based on κ we have $\omega \prec_{\Pi} \omega'$ implies $\omega \prec_{\kappa} \omega'$ and thus \prec_{κ} is compatible to Π . Let $\mathfrak{R}(\prec_{\Pi})$ be the set of all ranking functions that are Π -compatible.*

This corollary follows from Theorem 1 directly, where the inequality in (5) allows for an infinite number of ranking functions satisfying the property of Π -compatibility. Algorithm 1 showed how to generate such a ranking function by setting preferences locally, using the successor relation on the set of natural numbers to obtain an OCF with ranks as small as possible in general while still satisfying the theorem. In contrast to this unique representation of the global preference, the set $\mathfrak{R}(\prec_{\Pi})$ is the set of all Π -compatible OCFs. The following algorithm sets up ordered partitions of $\Omega = \Omega_0 \cup \Omega_1 \cup \dots \cup \Omega_m$ from \prec_{Π} with the property that $\kappa(\omega) < \kappa(\omega')$ for all $\omega \in \Omega_i$ and $\omega' \in \Omega_j$ with $j > i$ which then serve as a base for generating any $\kappa^{(i)} \in \mathfrak{R}(\prec_{\Pi})$ that is compatible to the global preference \prec_{Π} .

Algorithm 2.

Input: CP-network $\Pi = \langle \Sigma, \mathcal{E}, \{CPT(V, pa(V))\}_{V \in \Sigma} \rangle$ with global preference \prec_{Π}

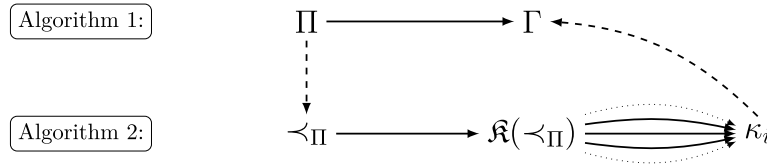

Fig. 8. Relations between Algorithm 1 and Algorithm 2.

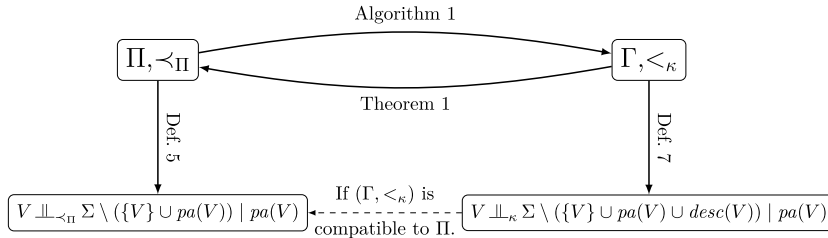

Fig. 9. Relationship between Markov Property and CP-independence for OCF- and CP-networks.

Output: family of Π -compatible OCF $\mathfrak{K}(\prec_{\Pi}) = \{\kappa^{(1)}, \dots\}$ which belong to strict OCF-networks $\Gamma = (\Sigma, \mathcal{E}, \{\kappa_V\}_{V \in \Sigma})$ compatible to Π

Let Π be a CP-network with a global preference \prec_{Π} which is shown to generate a schema for Π -compatible OCF-networks. Let $\Omega_0, \dots, \Omega_m$ be a partitioning of Ω such that $\Omega_0 = \{\omega \mid \nexists \omega' \in \Omega : \omega' \prec_{\Pi} \omega\}$ and for each $1 \leq i \leq m$ set $\Omega_i = \{\omega \mid \nexists \omega' \in \Omega \setminus \bigcup_{j=0}^{i-1} \Omega_j : \omega' \prec_{\Pi} \omega\}$.

- Assign $\kappa(\omega^{(0)}) = 0$ to all $\omega^{(0)} \in \Omega_0$.
- For each $1 \leq i \leq m$ assign $\kappa(\omega^{(i)}) = k$ to all $\omega^{(i)} \in \Omega_i$ s.t. $k > \max_{\omega^{(i-1)} \in \Omega_{i-1}} \{\kappa(\omega^{(i-1)})\}$.
- After $\kappa(\omega)$ is set for every ω , generate κ_V from κ such that $\kappa_V(V(\omega) \mid pa(V)(\omega)) = \kappa(\{V\} \cup pa(V)(\omega)) - \kappa(pa(V)(\omega))$ by definition of conditional ranks and (3).

So with Algorithm 1 we can generate a unique compatible OCF-network to a CP-network Π , while Algorithm 2 generates a family of Π -compatible OCF $\mathfrak{K}(\prec_{\Pi})$ which can be used to generate OCF-networks on the graphical structure provided by Π . Fig. 8 illustrates how both algorithms are related.

Extending \prec_{Π} to \preceq_{Π} with $\omega \preceq_{\Pi} \omega'$ if $\omega \prec_{\Pi} \omega'$ or $\{\omega'' \mid \omega'' \prec_{\Pi} \omega\} = \{\omega'' \mid \omega'' \prec_{\Pi} \omega'\}$ and $\{\omega'' \mid \omega \prec_{\Pi} \omega''\} = \{\omega'' \mid \omega' \prec_{\Pi} \omega''\}$ (in the latter case we write $\omega \sim \omega'$) is therefore a possible extension. With \preceq_{Π} we can further formalise the result that an OCF-network is compatible to a CP-network with global indifference if it is compatible with the CP-network according to Definition 13, and we have $\kappa(\omega) = \kappa(\omega')$ if $\omega \sim \omega'$ which is already ensured by Algorithm 2.

OCF-networks satisfy the local directed Markov Property (4). This property defines a relation between sets of vertices which are disjoint subsets of all vertices in the graph. Therefore, this the property has no direct counterpart in CP-networks, which describe relations between some partitions of the vertices. In the following we sketch why both independence properties are different in general. Let Π be a CP-network and Γ be the Π -compatible OCF-network generated with Algorithm 1. Let $V \in \Sigma$ be a vertex with $\mathbf{p} \in \Omega_{pa(V)}$, $\mathbf{d} \in \Omega_{desc(V)}$ and $\mathbf{n} \in \Omega_{nd(V)}$. For Π we have $\dot{v} \prec_{\mathbf{p}} \bar{v}$ if and only if $\dot{v} \mathbf{p} \mathbf{d} \mathbf{n} \prec_{\Pi} \bar{v} \mathbf{p} \mathbf{d} \mathbf{n}$ by Definition 3. We also have that $\dot{v} \prec_{\mathbf{p}} \bar{v}$ is equivalent to $\kappa(\dot{v} \mid \mathbf{p}) < \kappa(\bar{v} \mid \mathbf{p})$ by construction. By the Markov Property (4) from the latter we obtain $\{V\} \perp_{\kappa} nd(V) \mid pa(V)$, which gives us $\kappa(\dot{v} \mid \mathbf{p}) = \kappa(\dot{v} \mid \mathbf{p} \mathbf{n})$ by conditional κ -independence (Definition 7) for every \mathbf{n} . Therefore we have $\kappa(\dot{v} \mid \mathbf{p} \mathbf{n}) < \kappa(\bar{v} \mid \mathbf{p} \mathbf{n})$ for any additional $\mathbf{n}' \in \Omega_{nd(V)}$. Since here a preference is preserved even if variables are configured differently, this does not hold for \prec_{Π} in general. On the other hand, CP-independence gives us $\dot{v} \mathbf{p} \mathbf{d} \mathbf{n} \prec_{\Pi} \bar{v} \mathbf{p} \mathbf{d} \mathbf{n}$ for constant \mathbf{d} , but since $desc(V)$ is not κ -independent from V , this preference does not hold for OCFs in general. Therefore the concepts of independence in CP- and OCF-networks are different in general.

Note that OCF-networks Γ which are compatible to a CP-network Π satisfy the property of conditional CP-independence because in this case $\prec_{\Pi} \subseteq \prec_{\kappa}$ as shown in Theorem 1. Figure 9 illustrates the relationships between the network approaches with respect to their independence properties.

With [13, Theorem 1] and Theorem 1 we obtain that for every OCF κ that is compatible to Π there are local OCF tables that mimic the local preference in the CPTs of Π . Therefore for every $\kappa \in \mathfrak{K}(\prec_{\Pi})$ there is an OCF-network with the same local and global properties as Π .

Overall with Corollary 2 we obtained that for each CP-network there is an OCF-network that is compatible to the CP-network, whereas the reverse is not true in general. This implies that the approach of OCF-networks is strictly more expressive than the approach of CP-networks.

But apart from preferential relations, the notion of firmness allows for OCF-networks (and the OCF approach in general) to express different degrees of disbelief, a notion shared by, e.g., probabilistics, possibilistics and fuzzy logic. This is not possible in CP-networks where only the fact that a world is preferred can be expressed, not, how strongly this happens (or how strongly the other is refused).

7. Synopsis

To summarise, first we have shown that since local ranking tables can express indifferences which CPTs cannot, as a first step in the mutual generation OCF-networks have to be restricted to *strict* OCF-networks (Definition 11). Since the underlying graph structures are identical, this restriction allows to generate either network type from the other (Propositions 1 and 2). However, even if capable of generating a network of the designated type, the plain approaches introduced in Section 5.1 fail to ensure that the *global* information is preserved in this process (Observations 1, 2, 3, 4), even if the approach ensures that the *local* preferences are preserved. Even if it is not to be expected that a plain, local approach is capable to preserve every property of every network approach in the process of mutual generation of networks, we could show that neither in the direction of OCF- to CP-networks nor in the direction of CP- to OCF-network the inferential properties are guaranteed to be preserved.

Apart from these findings, the analysis of the plain approach provided valuable insights which we afterwards used to come up with ways to overcome these difficulties, partially. Corollary 1 shows that due to the property of Π -compatibility (Definition 13, Theorem 1), each CP-network can be translated into an OCF-network, overcoming the problems of the plain approach found in Observation 3. Theorem 2, together with Algorithm 1, gives a construction plan for such a Π -compatible OCF-network, whereas Corollary 2 shows that, given a specific CP-network, there are infinitely many Π -compatible OCF-networks which can be constructed from it by Algorithm 2. For the other direction, that is, translating OCF-networks into CP-networks, however, there is no such escape from Observation 4, that is, there are OCF-networks that cannot be translated into CP-networks. Therefore OCF-networks are strictly more expressive than CP-networks.

8. Other network approaches

As mentioned in the introduction, approaches to represent knowledge with networks are manifold, and may get along with CP-networks.

Ordinal conditional functions rank the plausibility of worlds by the set of ordinals, which are discreet and possess a unique successor, each. OCFs also are normalised such that there is a (local) world which is maximally believed in every ranking (or ranking table) and by thus has the rank of 0. With these properties, a ranking function according to Theorem 1 could be instantiated from a CP-network with Algorithm 1. For approaches which express belief or plausibility by means of numbers from the continuous interval $[0, 1]$, this cannot be done this easily.

It has been shown that the global preference induced by CP-networks can be expressed using possibilistic logic [11], whilst the authors leave open the question whether there is an exact representation of CP-networks in possibilistic networks. Possibilistic representation allows to assign the most plausible value to the preferred configuration, as it is done for OCFs (but here the scale is reversed). For concrete local preferences represented by possibilistic logic in the sense of Theorem 1, we would expect that the distance to 1 should increase with every child of a vertex in the sense of Algorithm 2.

There is a relation between ordinal conditional functions and possibility theory [26]. Also, both possibilistic and OCF-networks have been developed in analogy to Bayesian networks [17], but there are subtle but critical differences to probability theory, for instance OCF-networks do not cover the inductive properties of Bayesian networks in general [13]. A thorough comparison of OCF- and product-based possibilistic networks [4,2] is part of our current work. We expect lots of similarities, at least on the surface. However, we will also consider advanced reasoning scenarios

like inductive reasoning and investigate network inferences in order to thoroughly elaborate both on potential and problems of both approaches. These areas are, as our findings for OCF- and Bayesian networks have shown, the ones where otherwise similar approaches may show crucial differences. For instance, even if OCF- and Bayesian networks share crucial formal properties, global ranking functions of OCF-networks that are built up from inductively generated local ranking functions by making use of (local) conditional knowledge bases are not guaranteed to be models of these local knowledge bases. This does not occur with Bayesian networks. For more detailed information, please see [17,18,13].

Nonetheless we assume that it is possible to capture most of the properties of either approach in the respective other for product-based possibilistic networks. Hence it seems safe to assume that the similarities found between OCF- and CP-networks are valid for CP- and product-based possibilistic networks (see also [6]), and vice versa, whilst we further assume that min-based possibilistic networks [5,1,3,11] might be different in general.

UCP-networks [8] are an extension of CP-networks that use numeric local utilities to encode the preference of an outcome of the variables in the context of their parents instead of using strict local preferences. The resulting preference relation is not strict but allows for indifference and the global utility is calculated using a summation over all variables of the network. The authors show that iff each variable of the network *dominates* its children with respect to the preference relation, the network is a valid CP-network for the global preference relation gained from the global utility. The concession of local indifference and the summation as operation for obtaining the global utility and thereby preference relation allows the assumption that both UCP- and OCF-networks are closer related than CP- and OCF-networks, which is strengthened by the notion of dominance that seems to resemble our property of Π -compatibility (Definition 13). A formal comparison of both approaches is part of our future work.

9. Conclusion

In this paper we presented two established network approaches to represent local preference or plausibility, CP-networks from decision making and OCF-networks from knowledge representation. We showed that there is an easy way to transfer the encoded information, locally, but demonstrated that this plain approach is bound to fail to transfer the global inferences, as well. We then presented a subclass of OCF-networks where the plain approach constructs CP-networks that are compatible with respect to inferential and preferential information to the original network and developed an algorithm to construct such an OCF-network from an arbitrary CP-network. This mutual construction of networks was completed with a comparison of both approaches where we showed that OCF-networks are strictly more expressive than CP-networks. Additionally, CP-networks lack the possibility to express degrees of plausibility or preference, a feature OCF-networks share with other successful approaches in knowledge representation.

From Sections 5 and 6 we obtained that (a subclass of) OCF-networks, which usually represent plausibility, can be used to represent information about preferences, as well. Anyhow, preference and plausibility are usually not the same and should not be confused. For instance, one might prefer to win a fortune in the lottery but nonetheless believe this to be quite implausible, or one might believe to plausibly develop cancer because of heavy smoking while not preferring it. The possibility to express the preferences of CP-networks in OCF-networks is of a high practical value, still: An intelligent agent may have a model of individual desires represented by preferences and beliefs about the world represented by a ranking function. Here, the fact that the most desired or preferred world is not believed to be the most plausible one will result in a plan and finally in a series of actions the agent undertakes to change the latter to match (or be closer to) the prior. For instance, to increase the plausibility of winning in the lottery, the agent might buy a ticket, or stop smoking to reduce the plausibility of getting cancer. Being able to express preference and plausibility (and thus the respective formalisms and mechanisms which include but are not limited to inference components, network approaches and preferential models) using the same framework in the implementation of an intelligent agent allows for a lightweight implementation which is easy to maintain while still relying on the strengths of both approaches. Here, a comparison with possibilistic influence or decision diagrams (cf., e.g., [24]) which are also able to handle beliefs about the world and preferences in the same framework would be interesting and is part of our future work.

It should be emphasized that transformations from one of the considered formalisms to the other are not trivial because the underlying semantics (plausibility vs. preference) are different. In particular, algorithms especially devoted to CP- or OCF-networks, respectively, cannot be applied offhandedly to the respective other network, but in general, a thorough transformation of the algorithm respecting the semantical specialities would be necessary.

Acknowledgements

We thank the anonymous referees for their valuable hints that helped us improving the paper. This work was supported by Grant KI 1413/5-1 to Gabriele Kern-Isberner from the Deutsche Forschungsgemeinschaft (DFG) as part of the priority program “New Frameworks of Rationality” (SPP 1516). Christian Eichhorn is supported by this grant. This article is based on and extends the bachelor thesis of Matthias Fey [14].

References

- [1] A. Ajroud, S. Benferhat, M. Omri, H. Youssef, On the use of guaranteed possibility measures in possibilistic networks, in: Proceedings of the Twenty Second International Florida Artificial Intelligence Research Society Conference, FLAIRS’09, 2009, pp. 517–522.
- [2] R. Ayachi, N. Ben Amor, S. Benferhat, Inference using compiled product-based possibilistic networks, in: S. Greco, B. Bouchon-Meunier, G. Coletti, M. Fedrizzi, B. Matarazzo, R. Yager (Eds.), *Advances in Computational Intelligence*, in: Communications in Computer and Information Science, vol. 299, Springer, Berlin, Heidelberg, 2012, pp. 470–480.
- [3] R. Ayachi, N. Ben Amor, S. Benferhat, A comparative study of compilation-based inference methods for min-based possibilistic networks, in: L. van der Gaag (Ed.), *Symbolic and Quantitative Approaches to Reasoning with Uncertainty*, in: Lecture Notes in Computer Science, vol. 7958, Springer, Berlin, Heidelberg, 2013, pp. 25–36.
- [4] R. Ayachi, N. Ben Amor, S. Benferhat, R. Haenni, Compiling possibilistic networks: alternative approaches to possibilistic inference, in: Proceedings of the 26th Conference on UAI, AUAI Press, 2010, pp. 40–47.
- [5] N. Ben Amor, S. Benferhat, K. Mellouli, Anytime propagation algorithm for min-based possibilistic graphs, *Soft Comput.* 8 (2003) 150–161.
- [6] N. Ben Amor, D. Dubois, H. Gouider, H. Prade, Possibilistic networks: a new setting for modeling preferences, in: U. Straccia, A. Cali (Eds.), *Proceedings of Scalable Uncertainty Management: 8th International Conference, SUM 2014*, Springer International Publishing, Cham, 2014, pp. 1–7.
- [7] S. Benferhat, K. Tabia, Belief change in OCF-based networks in presence of sequences of observations and interventions: application to alert correlation, in: B.T. Zhang, M. Orgun (Eds.), *PRICAI 2010: Trends in Artificial Intelligence*, in: Lecture Notes in Computer Science, vol. 6230, Springer, Berlin/Heidelberg, 2010, pp. 14–26.
- [8] C. Boutilier, F. Bacchus, R.I. Brafman, UCP-networks: a directed graphical representation of conditional utilities, in: Proceedings of the 17th Conference in Uncertainty in Artificial Intelligence, Morgan Kaufmann Publishers, Inc., San Francisco, CA, USA, 2001, pp. 56–64.
- [9] C. Boutilier, R.I. Brafman, C. Domshlak, H.H. Hoos, D. Poole, CP-nets: a tool for representing and reasoning with conditional ceteris paribus preference statements, *J. Artif. Intell. Res.* 21 (2004) 135–191.
- [10] A. Darwiche, M. Goldszmidt, On the relation between kappa calculus and probabilistic reasoning, in: Proceedings of the Tenth Conference on Uncertainty in Artificial Intelligence, UAI1994, 1994, pp. 145–153.
- [11] D. Dubois, H. Prade, F. Touazi, Conditional preference nets and possibilistic logic, in: L. van der Gaag (Ed.), *Symbolic and Quantitative Approaches to Reasoning with Uncertainty*, in: Lecture Notes in Computer Science, vol. 7958, Springer, Berlin, Heidelberg, 2013, pp. 181–193.
- [12] C. Eichhorn, G. Kern-Isberner, LEG networks for ranking functions, in: E. Fermé, J. Leite (Eds.), *Logics in Artificial Intelligence*, in: Lecture Notes in Computer Science, vol. 8761, Springer International Publishing, 2014, pp. 210–223.
- [13] C. Eichhorn, G. Kern-Isberner, Using inductive reasoning for completing OCF-networks, in: Special JAL Issue dedicated to Uncertain Reasoning at FLAIRS, *J. Appl. Log.* 13 (2015) 605–627.
- [14] M. Fey, *Qualitative Semantiken für DAGs – ein Vergleich von OCF- und CP-Netzwerken*, Bachelor thesis, Technische Universität Dortmund, Dortmund, Germany, 2012 (in German).
- [15] M. Goldszmidt, Fast belief update using order-of-magnitude probabilities, in: Proceedings of the Eleventh Conference on Uncertainty in Artificial Intelligence, UAI1995, 1995, pp. 208–216.
- [16] M. Goldszmidt, J. Pearl, Qualitative probabilities for default reasoning, belief revision, and causal modeling, *Artif. Intell.* 84 (1996) 57–112.
- [17] G. Kern-Isberner, C. Eichhorn, Intensional combination of rankings for OCF-networks, in: C. Boonthum-Denecke, M. Youngblood (Eds.), *Proceedings of the 26th International FLAIRS Conference, FLAIRS-2013*, AAAI Press, 2013, pp. 615–620.
- [18] G. Kern-Isberner, C. Eichhorn, OCF-Networks with missing values, in: C. Beierle, G. Kern-Isberner (Eds.), *Proceedings of the 4th Workshop on Dynamics of Knowledge and Belief, DBK-2013*, FernUniversität in Hagen, 2013, pp. 46–60.
- [19] G. Kern-Isberner, C. Eichhorn, Structural inference from conditional knowledge bases, in: M. Unterhuber, G. Schurz (Eds.), *Special Issue Logic and Probability: Reasoning in Uncertain Environments*, *Stud. Log.* 102 (2014) 751–769, Springer Science+Business Media, Dordrecht, NL.
- [20] G. Kern-Isberner, M. Thimm, M. Finthammer, J. Fissler, Mining default rules from statistical data, in: Proceedings of the Florida Artificial Intelligence Research Society Conference, 2009, pp. 541–546.
- [21] D.J. Lehmann, M. Magidor, What does a conditional knowledge base entail? 2002, CoRR cs.AI/0202022.
- [22] D. Makinson, General patterns in nonmonotonic reasoning, in: D.M. Gabbay, C.J. Hogger, J.A. Robinson (Eds.), *Handbook of Logic in Artificial Intelligence and Logic Programming*, vol. 3, Oxford University Press, Inc., New York, NY, USA, 1994, pp. 35–110.
- [23] J. Pearl, *Probabilistic Reasoning in Intelligent Systems: Networks of Plausible Inference*, revised second printing ed., Morgan Kaufmann Publishers, Inc., San Francisco, USA, 1988.
- [24] R. Sabbadin, H. Fargier, J. Lang, Towards qualitative approaches to multi-stage decision making, *Int. J. Approx. Reason.* 19 (1998) 441–471.
- [25] W. Spohn, Ordinal conditional functions: a dynamic theory of epistemic states, in: *Causation in Decision, Belief Change and Statistics: Proceedings of the Irvine Conference on Probability and Causation*, Springer Science+Business Media, Dordrecht, NL, 1988, pp. 105–134.
- [26] W. Spohn, *The Laws of Belief: Ranking Theory and Its Philosophical Applications*, Oxford University Press, 2012.